



# Aventa comfort AU

**AUS** **Operating instructions**  
**Installation instructions**

Page 2

Page 10

To be kept in the vehicle!

## Contents

Symbols used .....	2
<b>Safety instructions</b> .....	2
<b>Notes on using air conditioning systems</b> .....	3

## Operating instructions

Remote control .....	4
Start-up .....	5
Switching on .....	5
Temperature .....	5
Mode .....	5
Fan .....	5
Sleep function .....	5
Switching off .....	5
Time .....	5
Timer ON / OFF .....	5
Ambient lighting .....	5
Reset .....	6
Resend .....	6
Setup .....	6
IR receiver and manual on / off .....	6
IR receiver / function indicator .....	6
Red LED illuminates .....	6
Air Distribution .....	6
IR remote control battery change .....	6
<b>Maintenance</b> .....	6
<b>Disposal</b> .....	6
<b>Accessories</b> .....	7
<b>Troubleshooting</b> .....	7
<b>Technical data</b> .....	7
Installation dimensions (in mm) .....	8
Clearance around the air conditioning system .....	8
Air inlets / outlets .....	8
Condensation traps .....	8
<b>Declaration of conformity</b> .....	9
<b>Truma warranty policy</b> .....	9

## Installation instructions

Scope of delivery .....	10
<b>Accessories for installation</b> (optional) .....	10
Intended use .....	10
<b>Selecting a location</b> .....	10
<b>Cut-out installation 400 x 400</b> .....	11
<b>Installation with new cut-out</b> .....	11
Preparation for power cable connection .....	12
Securing the device .....	12
Use of roof thickness adapters .....	12
Securing the air distributor .....	13
Inserting the filters .....	13
230 V electrical connection .....	13
Function test / remote control mounting .....	13

## Symbols used



The device must only be installed and repaired by an expert.



Symbol indicates a possible hazard.



Note containing information and tips.

## Safety instructions



Repairs may only be carried out by an expert!

To avoid transportation damage, the device may only be sent to the Truma Service Centre if agreed beforehand.

The power supply must be disconnected from the mains (all poles) before opening the housing.

The device fuses and connection cables must only be replaced by experts.

The 230 V, T 6.3 A H (slow) device fuse can be found on the electronic control unit in the device and must always be replaced with an identical fuse.

Guarantee claims, warranty claims and acceptance of liability will be ruled out in the event of the following:

- changes to the device (including accessories),
- failure to use original Truma parts as replacement parts and accessories,
- failure to follow the installation and operating instructions.

Such changes or non-compliance also invalidate the device operating permit, which in many countries also denotes expiry of the vehicle operating permit.

The refrigerant circuit contains R 407C refrigerant and must only be opened **in the factory**.

The air inlets / outlets at the external unit and the air distributor must not be obstructed under any circumstances. This is essential in order to ensure that your device operates correctly.

In order to avoid damage to the compressor, no uphill or downhill slopes with an incline of more than 8 % must be driven on when the device is being operated while driving (e.g. with generator or voltage converter).

Do not operate the device in cooling mode for long periods with the vehicle at an angle, since the condensation that is produced may not be able to run away and may penetrate the vehicle if the circumstances are unfavourable.

For problem-free operation and in order to avoid damage, the supply voltage must always come from a source with a sine wave curve (e.g. voltage converter, generator) and without voltage spikes.

When the vehicle is being cleaned it must be ensured that no water gets into the device when spraying with a high-pressure cleaner, for example (do not spray directly into the openings of the device).

Hot cleaners and steam cleaners must **not** be used.

Condensation traps must always be unobstructed.

## Notes on using air conditioning systems

The air conditioning system is designed for a power consumption of up to 4.2 A. You should still check whether the camp site has adequate fuse protection (min. 6 A) before starting the equipment up.

Park the vehicle in the shade if possible.

Darkening with blinds reduces the amount of heat insolation.

Clean your roof at regular intervals (dirty roofs heat up more than clean roofs).

Ventilate your vehicle well before starting the equipment in order to remove accumulated warm air from the vehicle.

In order to obtain a healthy room climate, the difference between the inside and outside temperatures should not be too great. The recirculated air is cleaned and dried during operation. A pleasant room climate is produced by drying the moist air, even with small temperature differences.

Keep all doors and windows closed when in cooling mode so that no condensation build-up occurs at the air distributor.

For faster cooling or heating:

- Set fan level to high,
- Set front / rear air distribution to centre position,
- Set floor / ceiling air distribution to ceiling.

## Remote control

**i** The symbols in the display are visible depending on the settings.

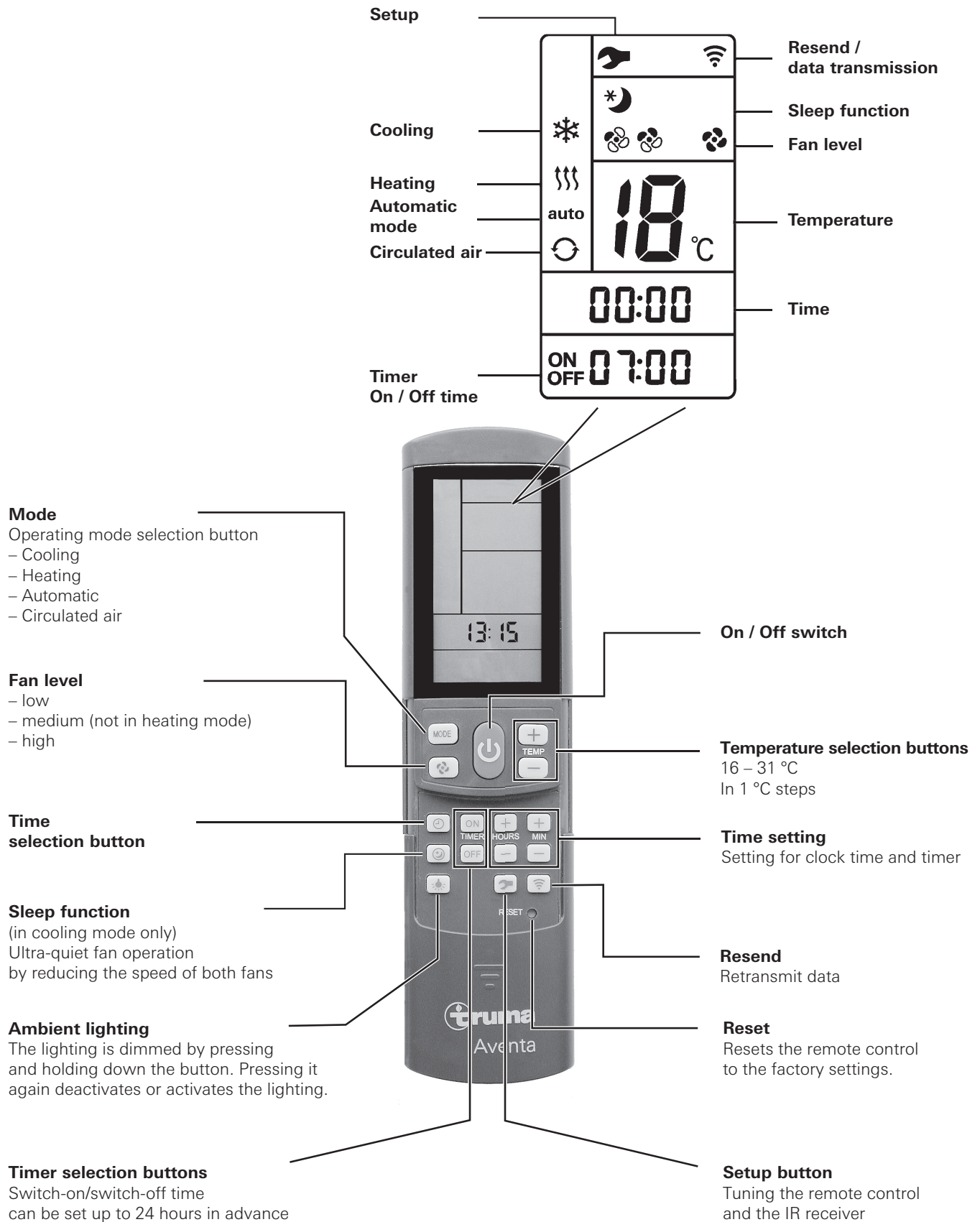



Fig. 1

## Start-up

Before switching on, be sure to check that the camp site power supply fusing is sufficient (230 V).

 In order to prevent the power cable of the recreational vehicle from overheating (minimum cross-section 3 x 2.5 mm<sup>2</sup>) the cable drum must be fully unwound.

The remote control must always be pointed at the infra-red receiver in order to perform the individual switching commands.

Before switching on for the first time, the remote control must be tuned to the IR receiver.

- Insert batteries (pay attention to polarity)
- Setup symbol flashes (if symbol does not flash, perform Reset)
- Point remote control at IR receiver
- Press Setup button and hold down
- When the red LED on the IR receiver starts to flash, release Setup button.

The remote control is tuned to the IR receiver, the setup symbol goes out and the air conditioning system starts in circulated air mode on the lowest fan level, with no timer set.

## Switching on

Switch on the air conditioning system using the **“On/Off switch”** of the remote control. The previous settings are taken over.

 The circulated air fan runs after switching on. The compressor activates itself after no more than 3 minutes and the blue (cooling) / yellow (heating) LED flashes.

## Temperature

If necessary, use the **“Temperature selection buttons”** to set the required room temperature with **“+”** and **“–”**.

## Mode

Select the required operating mode by pressing the **“MODE”** button one or more times.

- Cooling
- Heating
- Automatic (cooling or heating mode, depending on the room temperature selected)
- Circulated air

When the room temperature that was selected using the remote control is reached in **cooling mode**, the compressor switches off and the blue LED in the IR receiver goes off. The circulated air fan continues to run in order to provide ventilation. If the room temperature setting is exceeded, the device automatically reverts to cooling mode.

 The air is dehumidified during cooling. If the air humidity in the vehicle is extremely high at the beginning of the cooling procedure, moisture can build up on the underside of the air distributor. The doors and windows should therefore be kept closed and the highest fan level selected.

When the room temperature selected using the remote control is reached in **heating mode**, the compressor switches off and the yellow LED lamp in the IR receiver goes off. The circulated air fan continues to run in order to provide ventilation. If the room temperature falls below the temperature selected, the device automatically reverts to heating mode.

 Heating at an outside temperature of less than 4°C is not possible because heating performance falls considerably. Between 4°C and 7°C the device switches briefly to defrosting processes. At above 7°C there are no restrictions on heating mode.

In **automatic mode**, cooling or heating mode and fan level are selected automatically according to the room temperature.

In **circulated air mode** the interior air is recirculated and cleaned by the filter. No LED's illuminate in the IR receiver.

## Fan

Select the required fan level by pressing the **“Fan level”** button one or more times.

**Fan level** (not functional in automatic mode):

- low
- medium (not in heating mode)
- high

## Sleep function

In **“sleep function”** (cooling mode only), the internal and external fans operate at slow speed and are therefore extremely quiet.

## Switching off

To switch off, press the **“On/Off switch”** on the remote control. The remote control and the device are switched off. The light can still be switched on and off using the **“Ambient lighting”** button.

 If the air conditioning system is switched on again, the blue / yellow LED flashes. The air circulation fan runs, and the compressor activates itself after no more than 3 minutes.

## Time

**Press “Time selection button”** and set current time using the “Time setting” buttons.

The time is always shown on the display (exception with ON / OFF timer).

The time must be reset after changing the batteries or after a daylight saving time change.

## Timer ON / OFF

With the integrated timer the On/Off time of the air conditioning system can be set in advance for a minimum of 15 minutes to a maximum of 24 hours, starting from the current time.

The device must be switched on using the remote control in order to program it.

Set required operating mode and room temperature.

Then select **TIMER ON** or **TIMER OFF** using the **“TIMER selection buttons”**. Set the required On/Off time using the **“Time setting”** buttons (15 minutes to 24 hours) and **confirm** with **TIMER ON** and **TIMER OFF**.

Pressing the relevant timer button again deactivates the timer function.

## Ambient lighting

Irrespective of whether the air conditioning system is operating, the lighting in the air distributor can be switched on or off by pressing the **“Ambient lighting”** button. The lighting is dimmed by pressing and holding down the **“Ambient lighting”** button. The previous setting is activated when it is switched on again.

## Reset

Resets the settings of the remote control to the factory settings when pressed using a ballpoint pen, for example. Setup symbol flashes.

## Resend

The previous settings are resent.

## Setup

Tune the remote control to the air conditioning system that is going to be operated. Settings set to "Circulated air", fan level low, no timer set.

## IR receiver and manual on / off

There is an additional pushbutton on the IR receiver (m), with which the unit can also be switched on and off without the remote control (e.g. with a ballpoint pen).

If the unit is switched on using this pushbutton, the system is automatically reset to the factory settings (automatic mode 22 °C).

## IR receiver / function indicator

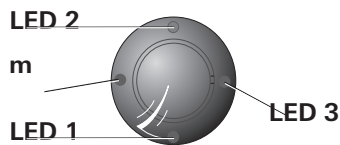

Fig. 2

LED 1 blue – illuminated – (cooling mode)  
LED 1 blue – flashing – (cooling mode compressor start-up)

LED 2 yellow – illuminated – (heating mode)  
LED 2 yellow – flashing – (heating mode compressor start-up)

LED 3 red – flashing – (data are being transmitted)  
LED 3 red – illuminated – (fault)

## Red LED illuminates

The device is indicating a fault. Switch device off, wait for a short time and switch on again. If the red LED continues to illuminate, please contact the Truma Service Centre.

## Air Distribution

### Right / left

There are two individually adjustable air outlets at the front and rear.

### Front / rear

The air flow can be metered between the front and rear areas of the vehicle.

### Ceiling / floor

The air flow can be directed from the ceiling to the floor.

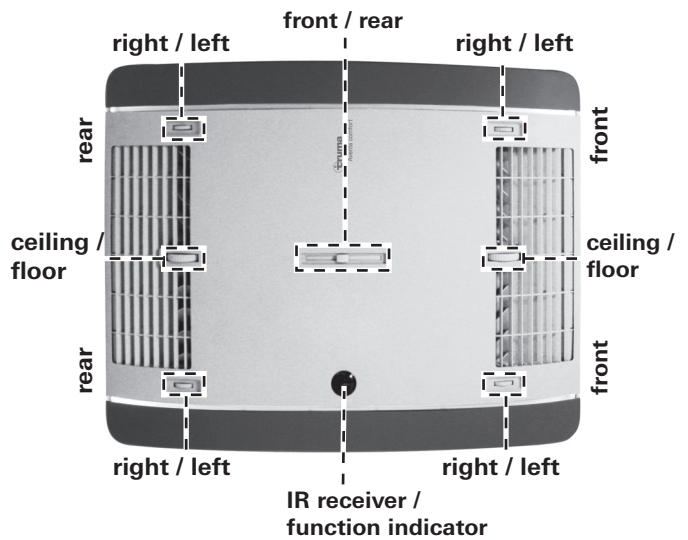

Fig. 3

## IR remote control battery change

Only use micro-batteries that will not leak, type LR 3, AM4, AAA, MN 2400 (1.5 V).

The battery compartment is on the back of the remote control.



When inserting new batteries, make sure the positive / negative terminals are connected correctly.



Empty, used batteries can leak and damage the remote control! Remove the batteries if the remote control is not being used for a long period of time.

Fig. 4

## No warranty given for damage caused by leaking batteries.

Before scrapping the remote control, always remove the batteries and dispose of them properly.



The tuning between the remote control and the air conditioning system is retained if the batteries are removed.

## Maintenance

Carry out filter changes depending on the amount of use, but at least every 12 months. Never operate the air conditioning system without a filter. This can lead to loss of power. Keep the air inlets / outlets and the condensation traps free of obstructions such as leaves at all times. The air conditioning system should only be cleaned with a soft, damp cloth.

## Disposal

The device must be disposed of in line with the administrative regulations of the respective country in which it is used. National regulations and laws (in Germany, for example, the End-of-life Vehicle Regulation) must be observed.

In other countries, the relevant regulations must be observed.

## Accessories

Filter set, 2 pieces (part no. 40091-16800).



Fig. 5

## Troubleshooting

Fault	Cause / Remedy
Device not cooling	<ul style="list-style-type: none"><li>– Thawing procedure in progress</li><li>– Remote control temperature setting reached or too high</li></ul>
Device not heating	<ul style="list-style-type: none"><li>– Defrosting process running (outside temperature between 4 °C and 7 °C)</li><li>– Outside temperature below 4 °C</li></ul>
Device cooling / heating inadequately or not at all	<ul style="list-style-type: none"><li>– Filter soiled, change filter.</li><li>– External air routes soiled / blocked</li></ul>
Moisture on underside of air distributor	<ul style="list-style-type: none"><li>– Close windows and doors and select high fan level</li></ul>
Water dripping out of air distributor	<ul style="list-style-type: none"><li>– Condensation trap on external unit blocked</li><li>– Seal between device and roof not intact</li><li>– System at too much of an angle</li></ul>
Remote control not working	<ul style="list-style-type: none"><li>– Check batteries in remote control and replace if necessary</li></ul>
Device not reacting to remote control commands	<ul style="list-style-type: none"><li>– Check whether there are obstructions between the remote control and the IR receiver</li><li>– Is the remote control tuned to the IR receiver? / tune remote control to IR receiver.</li></ul>

**If these actions do not remedy the problem, please contact Service Australia.**

## Technical data

Determined on the basis of EN 14511 or Truma test conditions.

### Power supply

230 V – 240 V ~, 50 Hz

### Power consumption

Cooling: 4.2 A

Heating: 3.7 A

### Starting current

28 A (150 ms)

### Cooling power

2.4 kW

### Heating power

1.7 kW (heat pump)

### Air volume flow

max. 400 m<sup>3</sup>/hr.

### Usage limits

+4 °C to 40 °C.

### Maximum angle during operation

8 %

### Weight

33 kg plus installation materials

### Dimensions (W x H x D)

External: 660 x 248 x 1008 mm

Internal: 523 x 46 x 670 mm

### Refrigerant

R 407C

### Refrigerant content

see type plate on unit



Right reserved to make technical changes!

## Installation dimensions (in mm)

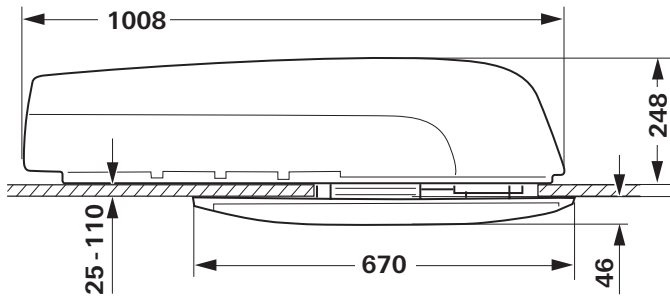

Fig. 6

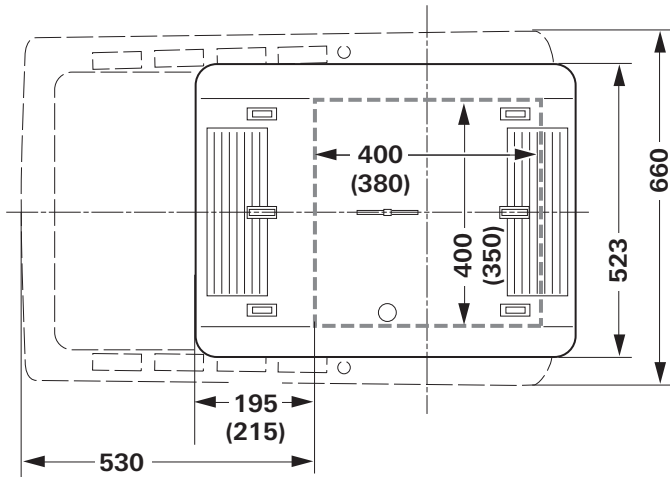

Fig. 7

## Clearance around the air conditioning system

The clearance around the **external unit** must be 20 mm at the front and 100 mm at the side. At least 30 mm of clearance must be left at the rear. Truma recommends clearance of 200 mm so that the exhaust air can blow out freely.

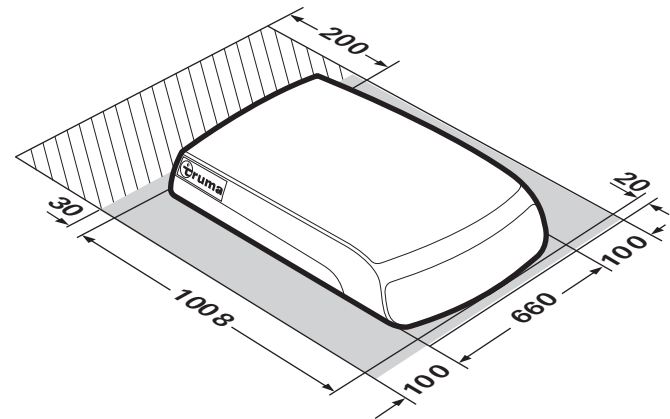

Fig. 8

The clearance around the **air distributor** must allow the air to blow out without obstructions. The side clearance must be at least 40 mm. The pivoting range of flaps and doors must be taken into consideration.

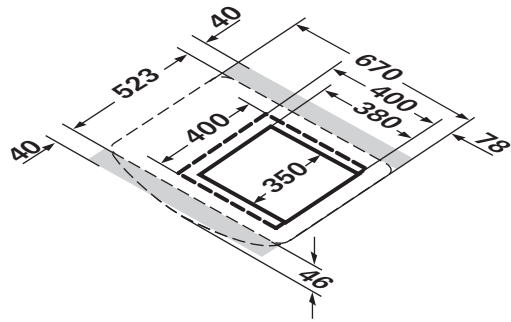

Fig. 9

## Air inlets / outlets

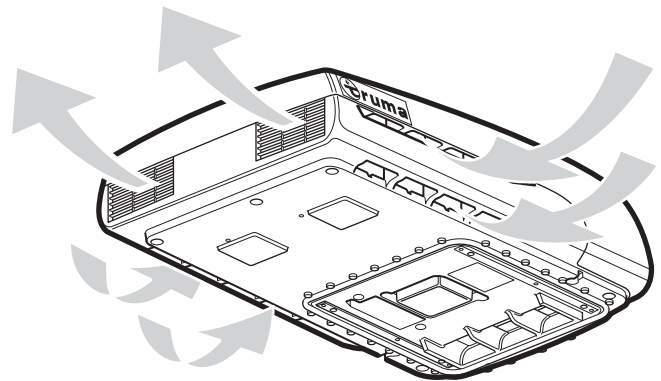

Fig. 10

## Condensation traps

The condensation is led away via the roof of the vehicle.

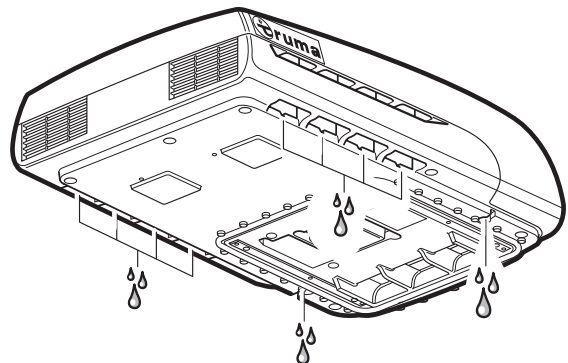

Fig. 11

Right reserved to make technical changes!



## Declaration of conformity

### 1. Information about the manufacturer

Name: Truma Gerätetechnik GmbH & Co. KG  
Address: Wernher-von-Braun-Str. 12, D-85640 Putzbrunn

### 2. Device identification

Type / model:

**Aventa comfort** air conditioning system

### 3. Complies with the requirements of the following EC directives

- 3.1 Electromagnetic compatibility 2004/108/EC
- 3.2 Low voltage directive (2006/95/EC)
- 3.3 Radio interference suppression of motor vehicles 72/245/EEC (with supplements), ECE Regulation R10 Revision 3
- 3.4 End-of-life vehicle directive 2000/53/EC

and bears the type approval number E24 10R-030696 and the CE symbol.

### 4. Basis of the proof of conformity

EN55014-1; EN61000-3-2; EN61000-3-3; EN62233:  
EN55014-2; IEC / EN60335-1; IEC / EN60335-2-40;  
2009/19/EC; DIN EN378-2;

### 5. Signatory details



Signature: p.p. Axel Schulz  
Product Centre Manager

Putzbrunn, 21.10.2013

## Truma warranty policy

The warranty is given by Service Australia for 12 months from the date of purchase against any defect arising from faulty materials or workmanship.

Repairs will be carried out during normal business hours only by Service Australia, or its duly authorised service agents, and are subject to the warranty conditions and exclusions hereunder.

### Warranty conditions

- The company will only provide service on presentation of proof of purchase, on either the Truma product, or the Caravan / RV / Pleasure Craft in which the Truma product has been installed, to any authorised service agent. The purchaser must allow the service agent to photocopy the proof of purchase to facilitate his claim to the manufacturer.
- Warranty repairs can only be performed by authorised service agents and under no circumstances will Service Australia reimburse repairs carried out by unauthorised persons. Tampering with any part of the product by unauthorised personnel will automatically void the warranty.
- The product must be used solely for domestic purposes only. If the product is used for commercial purposes the warranty is 6 months only.
- Where applicable, the products must be used on the appropriate electrical voltage, gas type and pressure, or fuel source.
- If at any time during the warranty period any part or parts are replaced with a part or parts not supplied or approved by Truma, this warranty shall immediately become void.

### Important notice

Before calling a service technician please check carefully the operating instructions, warranty terms and conditions. If the product fails for any of the reasons detailed therein, or is faulty due to abuse, misuse or improper installation, then a service fee shall be charged to the purchaser.

If you have any queries regarding the interpretation of the warranty you should contact Service Australia.

Whilst this book represents service outlets at the time of printing, changes occur from time to time. Should you have any queries or wish to locate your nearest authorised service agent please contact Service Australia.

### Warranty does not cover

- Any appliance which has been:
  - (a) Subject to misuse, neglect, accident or alteration by any person.
  - (b) Damaged or destroyed by fire, flood, act of God or other inevitable accident.
- Fair wear and tear.
- Damage from foreign substances such as dirt or liquid.
- Travelling expenses or call out fee to and from authorised service agents premises.
- Accommodation or Site Expenses.
- Cleaning of the system. This is considered to be a part of normal product maintenance.
- Non operation of the appliance or resultant damage to the unit where the appliance has been operated in an out of level situation.
- Freight cost of the appliance or parts, to or from, point of service or transit damage.
- Service Australia / Truma are not responsible for resultant loss or damage sustained by the purchaser.
- Non operation of the appliance or resultant damage to the unit where the appliance has not been installed, ventilated, flued or operated in accordance with the manufacturers instructions.

Apart from any warranties implied by the Trade Practices Act 1974 or any relevant State legislation all other warranties express or implied whether arising by virtue of statute or otherwise are hereby excluded.

## Installation instructions



Fig. 12

### The unit must only be installed and repaired by an expert.

Read the installation instructions carefully before commencing the work, and then comply with them!

### Scope of delivery

#### External unit:

- 1 Aventa comfort
- 2 brackets
- 4 screws M6 x 70 coated with screw sealant
- 6 screws M6 x 12 coated with screw sealant
- 1 base ring
- 2 roof thickness adapters (each 10 mm)
- 1 remote control with mounting
- 2 screws 2.9 x 16 for mounting
- 2 AAA batteries
- 1 set of operating and installation instructions
- 1 installation template
- 3 Wago clamps

#### Air distributor (must be ordered separately)

- 1 air distributor, fully assembled

### Accessories for installation (optional)

Roof thickness adapter 10 mm, 1 pc. (part no. 40091-16900)

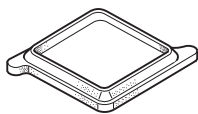

Fig. 13

Sealing frame (part no. 40091-19500)

Recommended for optimum sealing when retrofitting in vehicles with 400 x 400 mm cut-out.

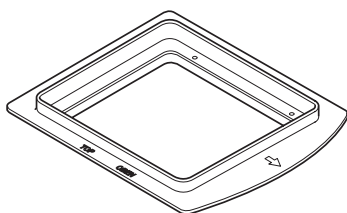

Fig. 14

Covering tape

cream (part no. 40091-31200)

grey (part no. 40091-31300)

For compensating for a gap of up to 5 mm between air distributor and roof.

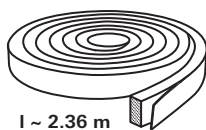

l ~ 2.36 m

Fig. 15

12 V adapter for air distributor lighting  
1 pc. (part no. 40091-33000)

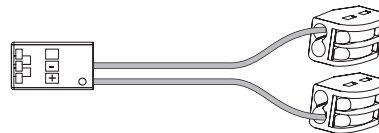

Fig. 16

### Intended use

This device has been designed for installation in motor homes and caravans and is intended for use in the private sector. Other applications are only permitted after prior consultation with Truma.

### Selecting a location

⚠ Once the roof-mounted air conditioning system has been installed, any nearby exhaust cowl must extend at least 10 cm above the air conditioning system. The exhaust cowl must be extended if necessary (pay attention to the heater manufacturer's specifications).

The roof of the vehicle (roof thicknesses of 25 to 110 mm) must be level and smooth.

Three installation options are available:

- The cut-out must be cut out again (350 x 380 mm).
- Cut-out of an existing roof hatch (400 x 400 mm) **without** a sealing frame (accessory).
- Cut-out of an existing roof hatch (400 x 400 mm) **with** a sealing frame (accessory). The installation instructions are included with the sealing frame.

#### Attention must always be paid to the following points:

- The device should be installed as close as possible to the centre of the vehicle.
- Check that no obstructions are present that will hinder installation.
- There may be electrical cables running between the interior and the exterior of the roof. Disconnect all voltage sources before starting the work (all poles).
- The roof load must not be exceeded (see vehicle manufacturer's specifications).
- Check interior installation site for obstructions.
- A wooden reinforcing frame (min. 25 mm) must be installed around the roof cut-out between the upper and lower surfaces of the roof. The insulation may have to be removed.

⚠ When the skylight with safety ventilation is replaced by the air conditioning system, it must be ensured that the safety ventilation is restored in another suitable location.

## Cut-out installation 400 x 400

For optimum sealing we recommend the use of the sealing frame that is available as accessory (part no. 40091-19000).

For installation with a sealing frame, please refer to the installation instructions provided with the sealing frame.

When installing the device in vehicles **with** an existing roof hatch, the cut-out must measure 400 x 400 mm.

Remove existing roof hatch (make cut-out bigger if necessary).

Remove sealant residue and unevenness.

Fill in screw holes with body sealant.

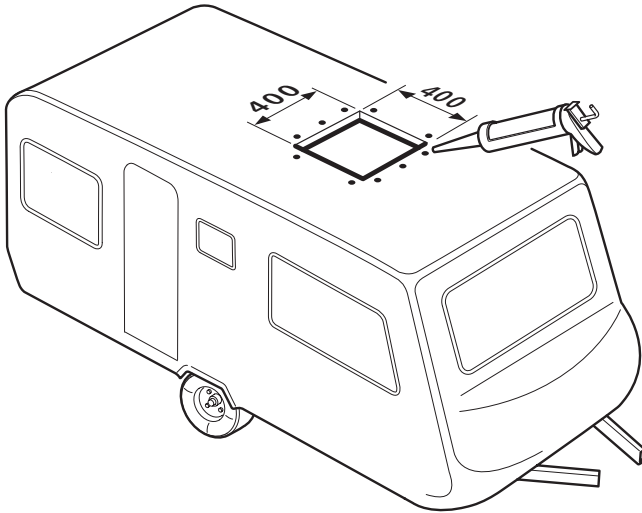

Fig. 17

For the other installation steps, please refer to "Preparation for power cable connection".

## Installation with new cut-out

For vehicles without an existing cut-out: required cut-out 350 x 380 mm.

Place template on installation location on vehicle, mark cutout (350 x 380 mm) and cut it out.

Mark the 4 holes (10 mm) for bracket attachment and drill holes in roof.

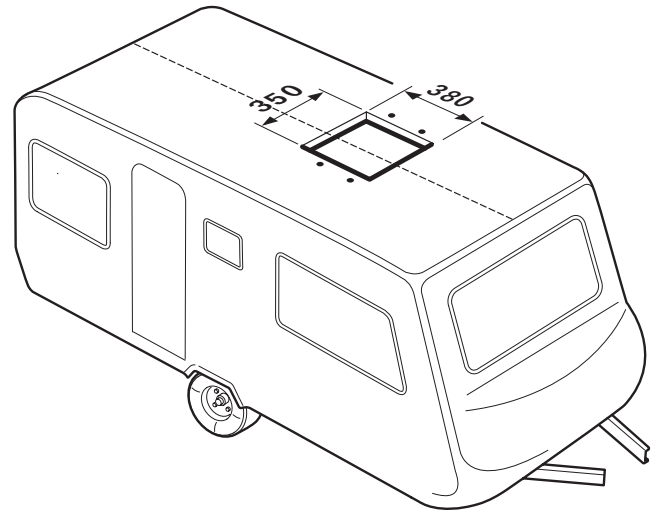

Fig. 18

## Preparation for power cable connection

Provide leadthrough for mains cable to connection point, e.g. in the false ceiling.

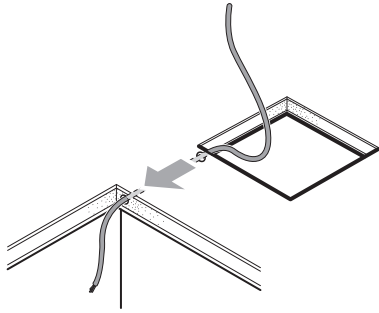

Fig. 19

Move device to roof in a horizontal position and insert into cut-out. The arrow should point in the direction of travel.

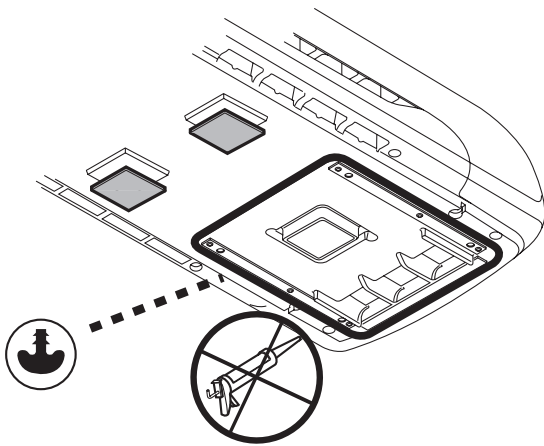

Fig. 20

- i** Do not apply any additional sealing materials between the air conditioning system and the roof.
- i** If the device was turned around or moved out of its horizontal installation position, wait 2 hours before switching it on.

Push device forwards in cut-out as far as it will go.

Remove protective film from device.

Route mains cable to connection point (lengthen cable with provided Wago clamps if necessary).

- i** If the lighting of the air distributor is also going to be optionally operated using 12 V, the 12 V adapter that is available as an accessory must now be connected. The installation instructions are provided with the 12 V adapter.

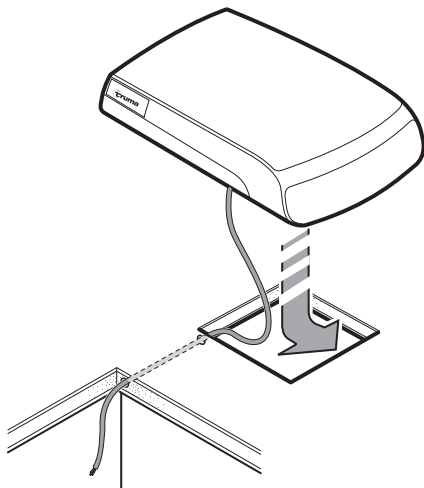

Fig. 21

## Securing the device

Screw the two brackets (marked with an arrow in the direction of travel) to the device using the 4 provided M6 x 70 screws (with screw sealant).

**Torque 1.8 Nm**

If the roof is more than 50 mm thick, M6 screws (length = roof thickness + 30 mm) with tensile strength of 8.8 must be used. The screws must be secured with low-strength screw sealant (e.g. Loctite).

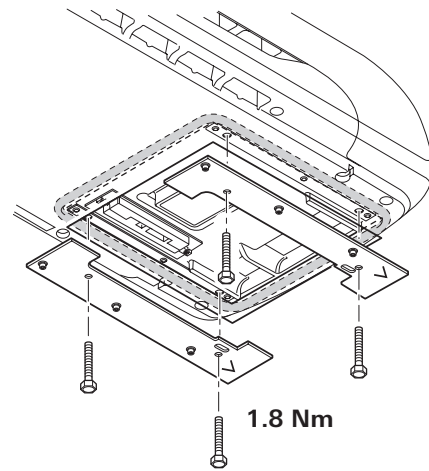

Fig. 22

- i** If the screws are used more than once (e.g. after removal) they must be coated with low-strength screw sealant again (e.g. Loctite) or the screws provided as spare parts used.

## Use of roof thickness adapters

Push base ring (1) and, depending on the thickness of the roof, the roof thickness adapters (2 or 2+3, included) for roof thicknesses of 25 to 50 mm into the air distributor as far as they will go. If the roof is thicker, use additional 10 mm roof thickness adapters (see accessories). Maximum roof thickness 110 mm

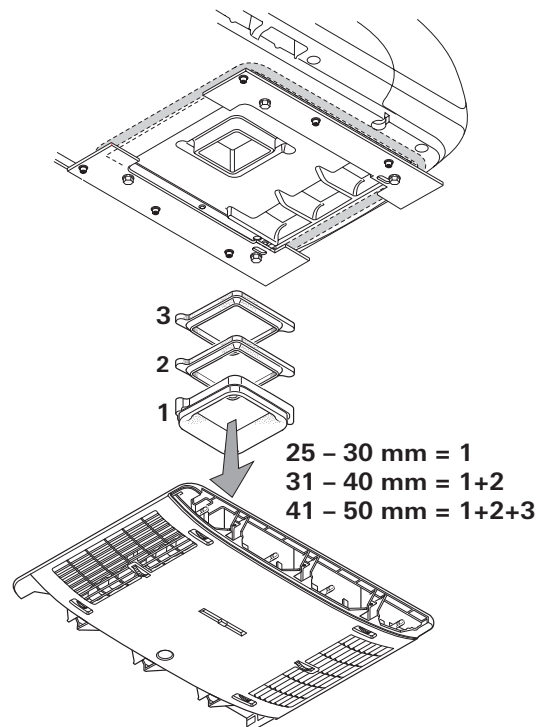

Fig. 23

## Securing the air distributor

Connect the cable from the air distributor to the electronics unit.

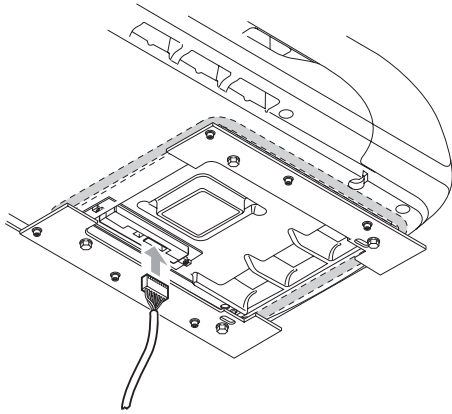

Fig. 24

Screw air distributor (arrow in direction of travel) to bracket with 6 screws M6 x 12 mm.

**i** The covering tape that is available as an accessory can be used to compensate for the gap between the air distributor and the roof.

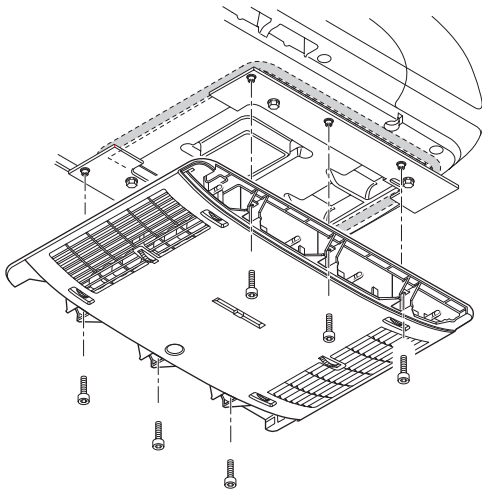

Fig. 25

**i** If the screws are used more than once (e.g. after removal) they must be coated with low-strength screw sealant again (e.g. Loctite) or the screws provided as spare parts used.

## Inserting the filters

Insert filters into panels and attach to the air distributor.

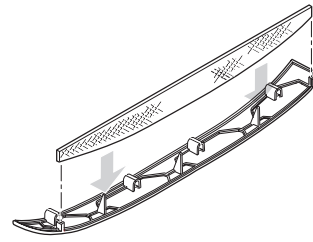

Fig. 26

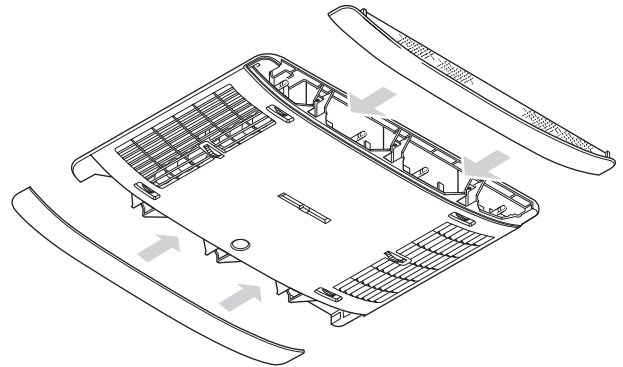

Fig. 27

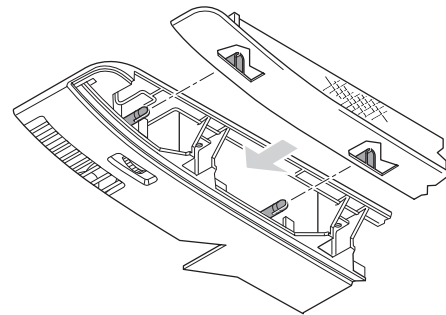

Fig. 28

## 230 V electrical connection

**!** The 230 V electrical connection must always be made by an expert (in accordance with VDE 0100, part 721 or IEC 60364-7-721, for example, in Germany). The instructions shown here do not constitute a request to non-experts to make the electrical connection, but serve as additional information for an expert who is employed to do the work!

Connect the mains cable that has been routed to the connecting point.

All cables must be secured with clamps!

An insulating device for providing all-pole insulation from the mains with contact clearance of at least 3.5 mm must be provided at the vehicle side for carrying out maintenance and repair work.

## Function test / remote control mounting

Attach the mounting for the remote control in the required location.

**All device functions must subsequently be tested as described in the operating instructions.**

The installer must check that the condensation traps are clear after installing the system.

The operating instructions must be handed over to the vehicle owner.







In Australia, always notify the Service Australia if problems are encountered; in other countries the relevant service partners should be contacted ([www.truma.com](http://www.truma.com)).

Having the equipment model and the serial number ready (see type plate) will speed up processing.