

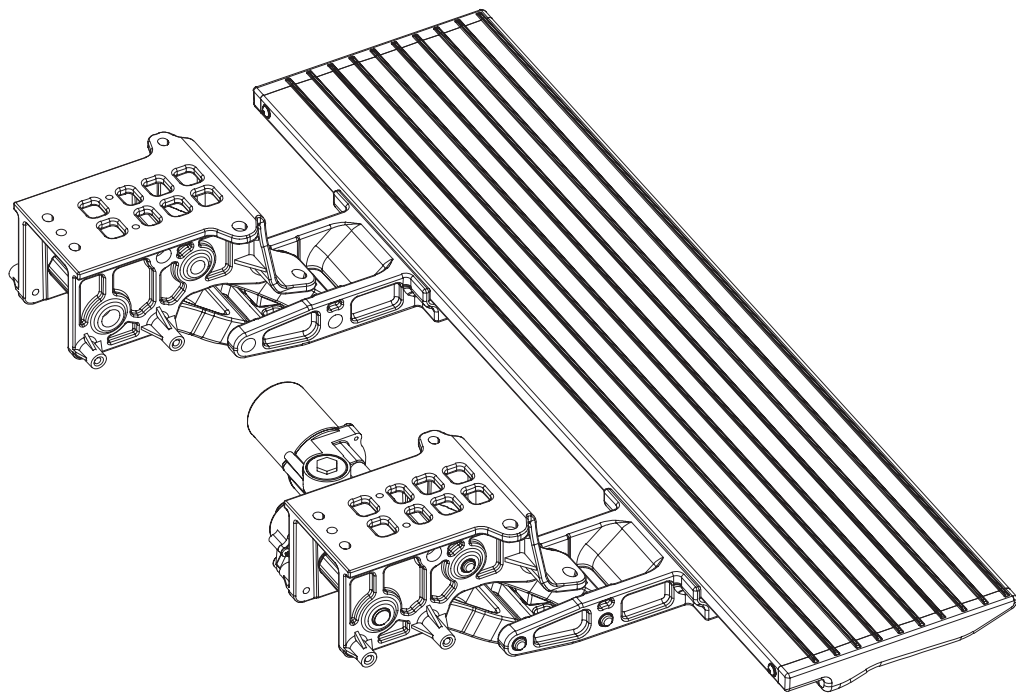

PREMIUM ELECTRIC DOOR STEP

INSTALLATION MANUAL



CONTENTS

USE	2
Parts List	2
Functions & Parameters	3
Cautions	4
Use of the Premium Electric Door Step	5
INSTALLATION	8
Installation Spec	8
Packing List	10
Premium Electric Door Step Installation	10
Trouble Shooting	13
WARRANTY STATEMENT	14



Read this installation instruction thoroughly.
Incorrect installation or operation may void any warranty.
Incorrect use or operation may cause serious injury.

PRODUCT INTRODUCTION

Enhance your caravan with the Aussie Traveller Premium Electric Door Step. This step has been designed to create an elevated experience to your trip away.

Automatically opening the step when you open the door means you don't have to look for the switch or manually open the step when leaving or entering your RV.

The Premium Electric Door Step is extremely durable while still coming in a sleek and luxurious matte black colour; it will withstand the rugged off road lifestyle and look great on your van.

Ask Aussie Traveller about the full range of RV steps available.



1300 663 868 | enquiries@aussietraveller.com.au | aussietraveller.com.au

BRISBANE SHOWROOM: 11-15 Oasis Court, Clontarf QLD 4019 | MELBOURNE SHOWROOM: 235 Barry Road, Campbellfield VIC 3061



PARTS LIST

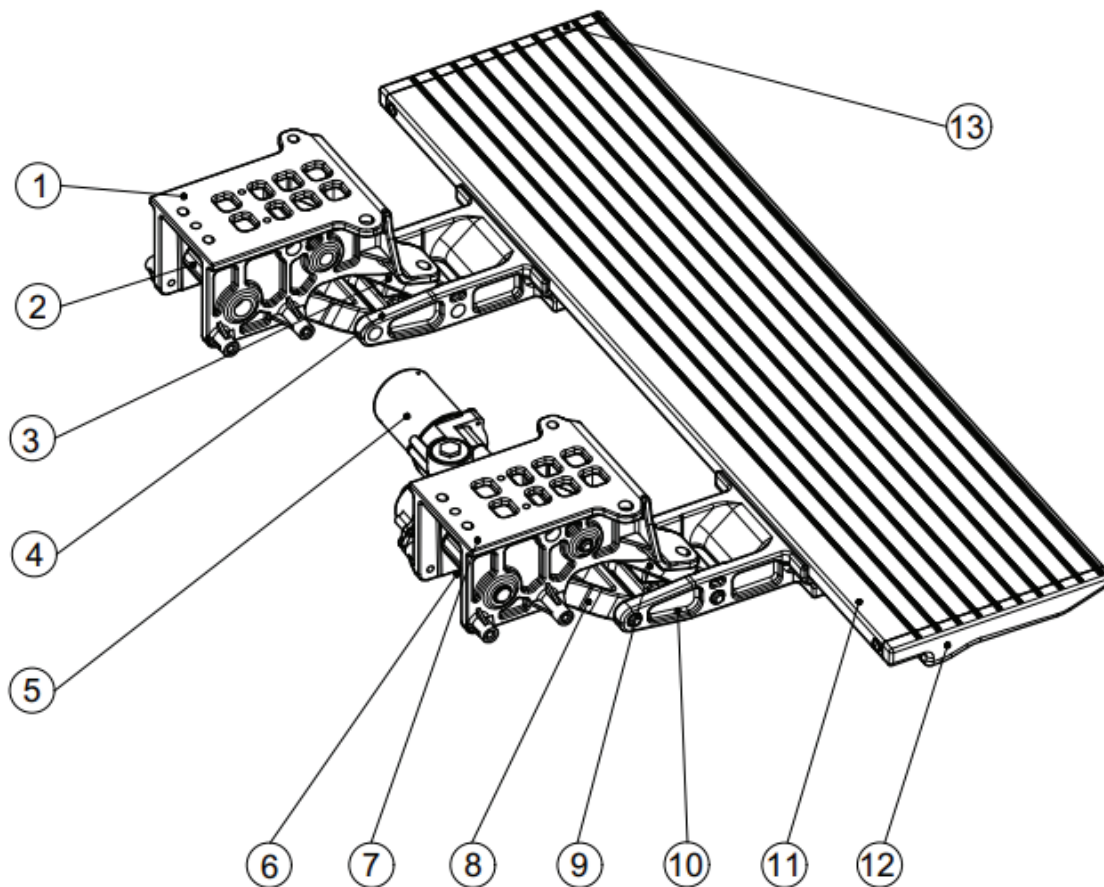

REFERENCE NUMBER	DESCRIPTION
1.	Fixed Supports (Left)
2.	Main Drive Swing Arm B
3.	Auxilliary Drive Swing Arm
4.	Step Supports (Left)
5.	Motor for Premium Electric Door Step
6.	Wedge Bolt
7.	Fixed Supports (Right)
8.	Main Drive Swing Arm A
9.	Auxilliary Drive Swing Arm
10.	Step Supports (Right)
11.	Step
12.	Step End Cap (Right)
13.	Step End Cap (Left)

1300 663 868 | enquiries@aussietraveller.com.au | aussietraveller.com.au

BRISBANE SHOWROOM: 11-15 Oasis Court, Clontarf QLD 4019 | MELBOURNE SHOWROOM: 235 Barry Road, Campbellfield VIC 3061

FUNCTIONS & PARAMETERS

FUNCTIONS FOR SAFETY & PROTECTION	
PROTECTION	The Door Step will be inextensible when the vehicle is linked to CAN/LIN signals and the driving speed is $\geq 8\text{km/h}$; the vehicle will be unable to be started under its own power when the EDS is extended;
ANTI-PINCH	In the process of being turned on/off, the EDS will retract back to the off/on position if the resistance $\leq 100\text{N}$;
VOLTAGE PROTECTION	When the input voltage of the EDS is $< 9\text{V}$ or $> 16\text{V}$, it will stop working, activating the voltage-protection in case of storage battery feeding and any damage to the EDS;
CENTRAL LOCKING PROTECTION	High level signal (unlocked) of the Central Locking Protection is the default signal. If the Central Locking line touches with the earth line, the signal of central locking line will be turned into low level signal(locked), retracting the EDS and locking its use.

PROPERTY PARAMETERS	
STEP SPEC. (W×L)	230×550mm
MOTION SPELL	2.0S for the EDS extension from beginning to the fullest extent and 2.0S for the EDS retraction from beginning to the fullest extent
VOLTAGE	Normal Voltage: 12V; Work Voltage: 6-12V (EDS stops working if the voltage $< 9\text{V}$ or $> 16\text{V}$)
ELECTRICAL CURRENT	Non-load current of the motor: 2A; Max Instantaneous Current $\leq 7\text{A}$; Locked Rotor Current $\leq 30\text{A}$
ANTI-PINCH FORCE	Protect users from being pinched as the EDS extends/retracts, with anti-pinch force $\leq 100\text{N}$
DOOR STEP ENDURANCE	100,000 cycles of extension and retraction without anomaly
WORKING NOISE	Motor noise $\leq 50\text{dB}$, overall noise $\leq 60\text{dB}$
WORKING TEMP	Working temp range for EDS: -40°C to 85°C
STATIC BEARING CAPACITY	Greater than 280kg
MOTOR PROTECTION GRADE	Protection Grade: IP67
VEHICLE COMMUNICATION INTERFACE	Communication Interface: CAN/LIN
SURFACE SPRAYING	Salt Spray Test for over 720h and no surface corrosion detected
H/L TEMP ENDURANCE	The machine could still perform the two states(extension/retraction) over 100 times respectively after being placed in an environment with a temp of -40°C for 40 hours, and then heated the environment to $(+23\pm 3)^{\circ}\text{C}$ and kept it there for 4 hours.
H/L TEMP SHOCK	The machine managed to demonstrate a smooth cycle of extension and retraction, and qualified anti-pinch force and the noise level;

1300 663 868 | enquiries@aussietraveller.com.au | aussietraveller.com.au





BRISBANE SHOWROOM: 11-15 Oasis Court, Clontarf QLD 4019 | MELBOURNE SHOWROOM: 235 Barry Road, Campbellfield VIC 3061

CAUTIONS

Please read over this manual before mounting and perform the mounting in strict accordance with the instructions. Keep the manual properly after reading.

Please obey the safety warnings and cautions in case of any injury or financial loss to the users or someone else.

SIGNS & CORRESPONDING MESSAGES

HAZARD SIGNAL	DEFINITION
	Caution! It's possible to cause severe injury or damage.
	Caution! It's possible to cause damage if the instructions are not followed in the operation process.
	This sign means such an operation is banned.
	This sign means a remark on related information.

WARNING

1. The installation of this product should be installed by professionals.
2. The manufacturer will not take on any responsibility if the product, damaged by external forces, is refitted without express permission of the manufacturer.
3. Please retract the EDS before driving the vehicle, Otherwise, it will be potentially hazardous to drive.
4. The distance of the EDS step and the bottom of the vehicle shell shall be $\geq 50\text{mm}$ in case the EDS pedal interferes with the vehicle shell when extending.
5. The distance of the bottom position of the moving EDS step and the floor shall be $\geq 50\text{mm}$ in case the step touches the floor when extending or retracting.
6. The EDS installation side on the chassis shall be guaranteed to be on the same horizontal level with the chassis, and the height error of both end of the installation side shall be $\leq 5\text{mm}$.
7. The power supply system of the vehicle shall be capable of supporting 30A current, the extension and retracting of the EDS generates Instantaneous Current of $\leq 7\text{A}$; Locked rotor current of the EDS is $< 30\text{A}$.

ATTENTION

1. Please consult Aussie Traveller if any malfunction occurs.
2. Please check whether the EDS has been properly retracted before driving and the commencement of your journey.
3. Please check the surrounding conditions as far as possible before using the EDS and guarantee a proper use of it.

1300 663 868 | enquiries@aussietraveller.com.au | aussietraveller.com.au

BRISBANE SHOWROOM: 11-15 Oasis Court, Clontarf QLD 4019 | MELBOURNE SHOWROOM: 235 Barry Road, Campbellfield VIC 3061

USE OF THE PREMIUM ELECTRIC DOOR STEP

DOOR SIGNAL SWITCH & CONTROL

Door Linked Switch	Door signal with black wires- red wires touching	Door signal with black wires- red wires detecting	Central Locking Signal wires connecting the earth wire
Corresponding Function	EDS extension	EDS retraction	EDS retraction and lock

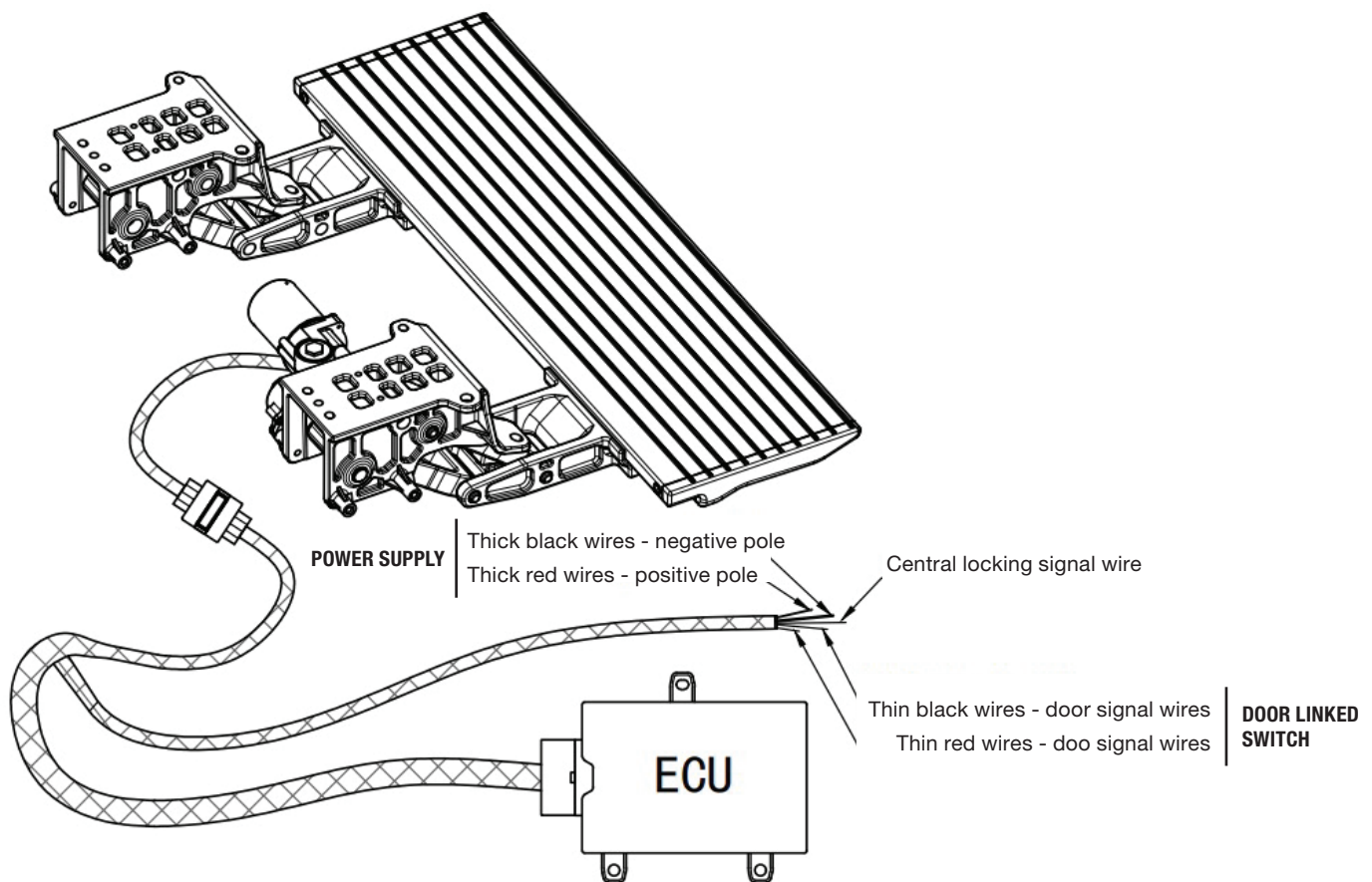

! **NOTE:** Please retract the EDS if you are to leave the vehicle for a long time!

1300 663 868 | enquiries@aussietraveller.com.au | aussietraveller.com.au

BRISBANE SHOWROOM: 11-15 Oasis Court, Clontarf QLD 4019 | MELBOURNE SHOWROOM: 235 Barry Road, Campbellfield VIC 3061

USE OF THE PREMIUM ELECTRIC DOOR STEP (cont.)

PREMIUM ELECTRIC DOOR STEP EXTENSION

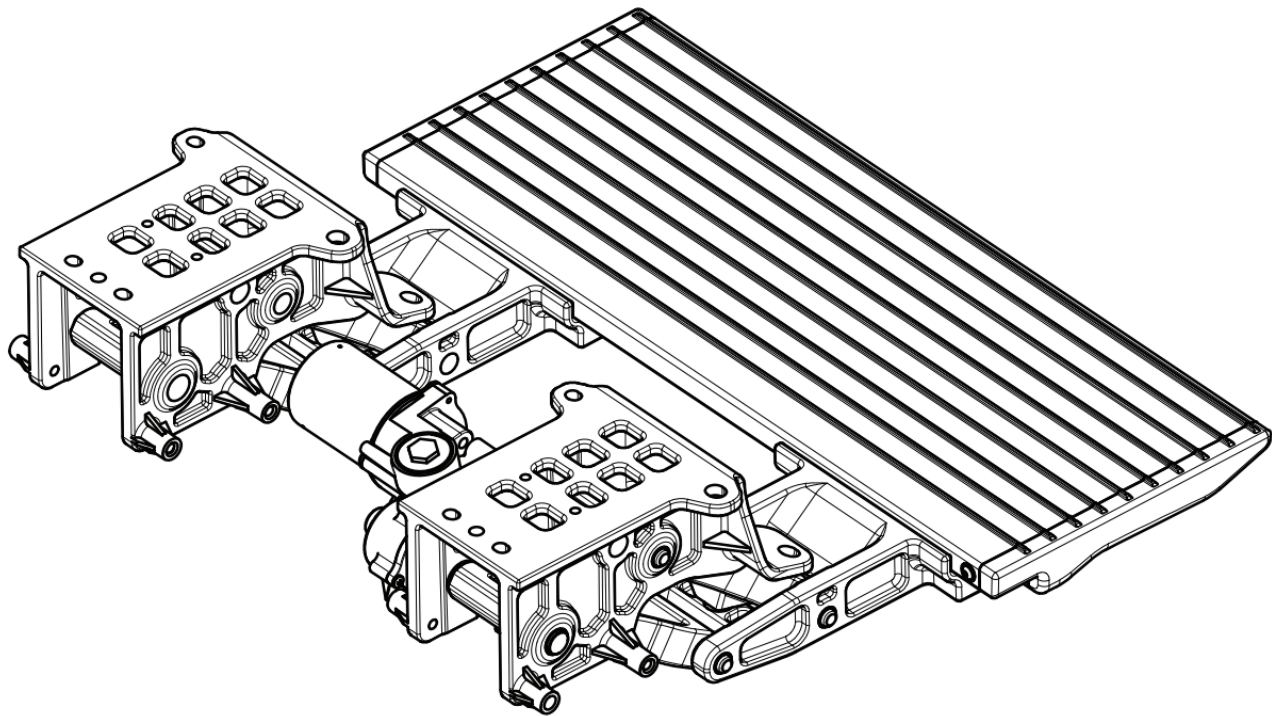
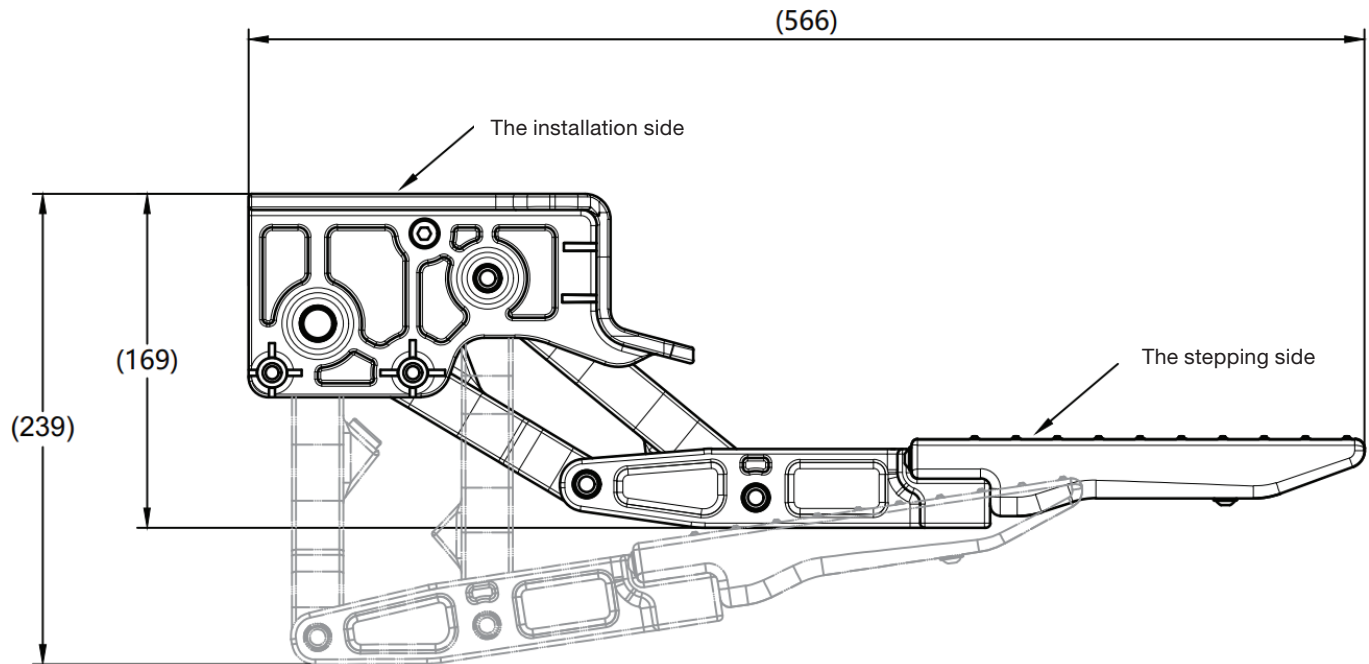

i **NOTE:** It's suggested to the users not to step onto the step until it's fully extended.

1300 663 868 | enquiries@aussietraveller.com.au | aussietraveller.com.au

BRISBANE SHOWROOM: 11-15 Oasis Court, Clontarf QLD 4019 | MELBOURNE SHOWROOM: 235 Barry Road, Campbellfield VIC 3061

USE OF THE PREMIUM ELECTRIC DOOR STEP (cont.)

PREMIUM ELECTRIC DOOR STEP RETRACTION

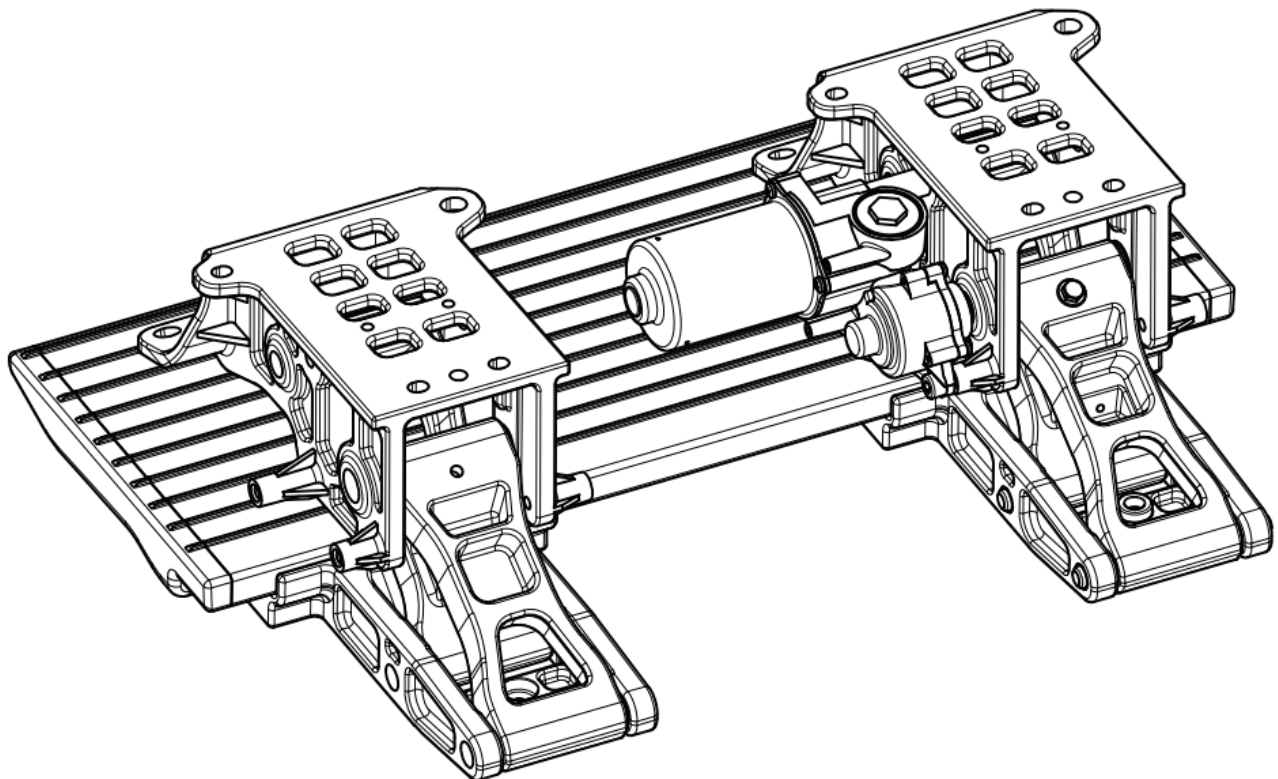
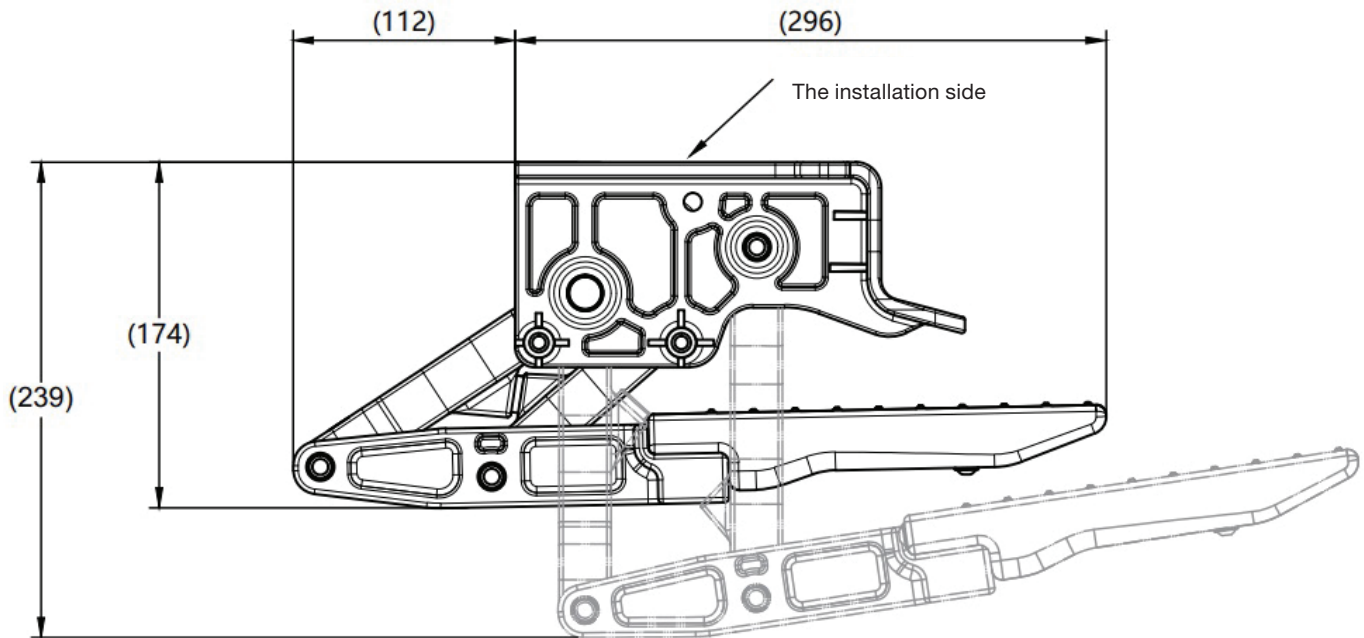

⚠ NOTE: Please make sure the Premium Electric Door Step is retracted before driving!

1300 663 868 | enquiries@aussietraveller.com.au | aussietraveller.com.au

BRISBANE SHOWROOM: 11-15 Oasis Court, Clontarf QLD 4019 | MELBOURNE SHOWROOM: 235 Barry Road, Campbellfield VIC 3061

INSTALLATION SPEC

PREMIUM ELECTRIC DOOR STEP

PART NUMBER: 40900010001080

Unit: mm

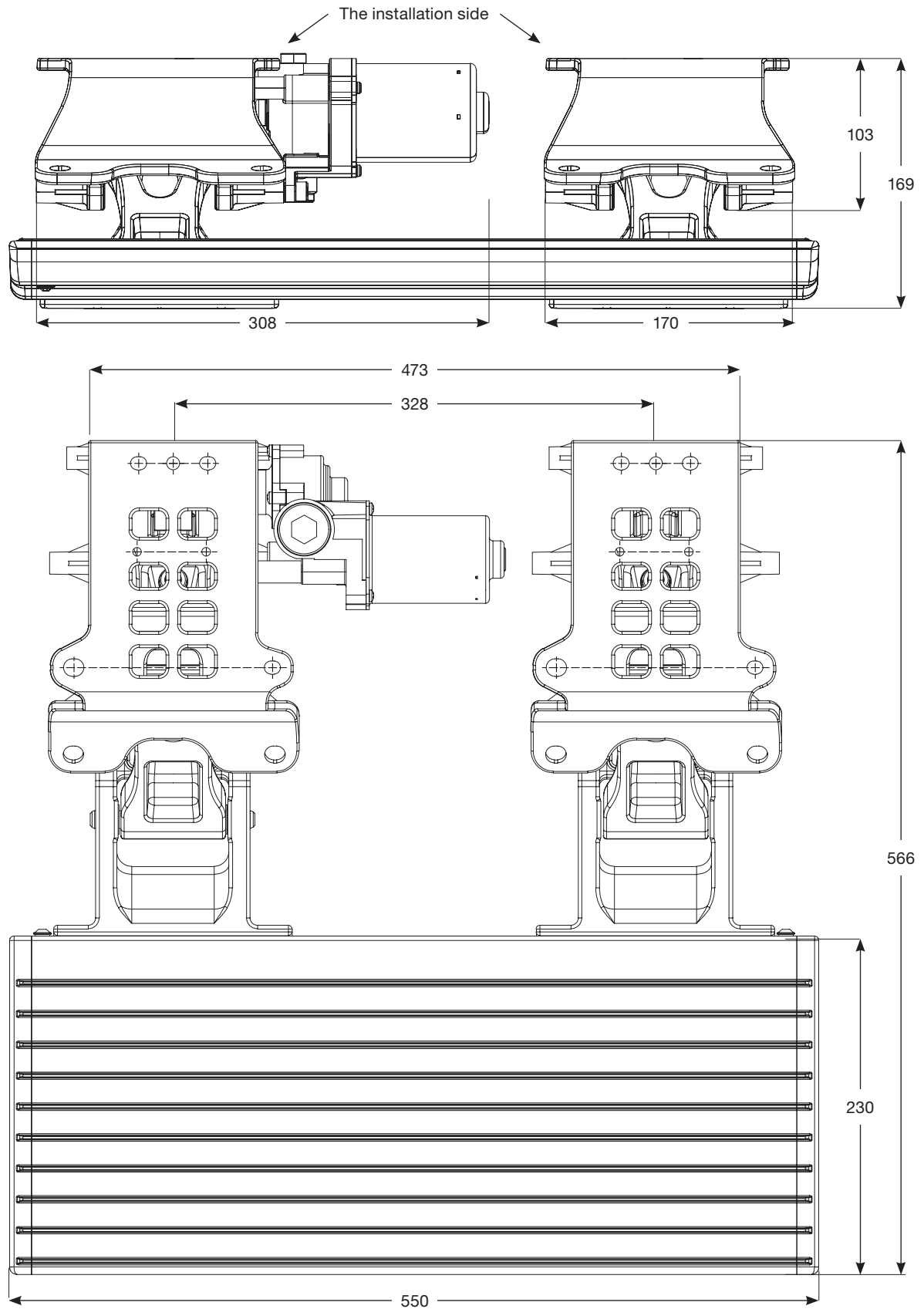

1300 663 868 | enquiries@aussietraveller.com.au | aussietraveller.com.au

BRISBANE SHOWROOM: 11-15 Oasis Court, Clontarf QLD 4019 | MELBOURNE SHOWROOM: 235 Barry Road, Campbellfield VIC 3061

INSTALLATION SPEC (cont.)

ECU

Unit: mm

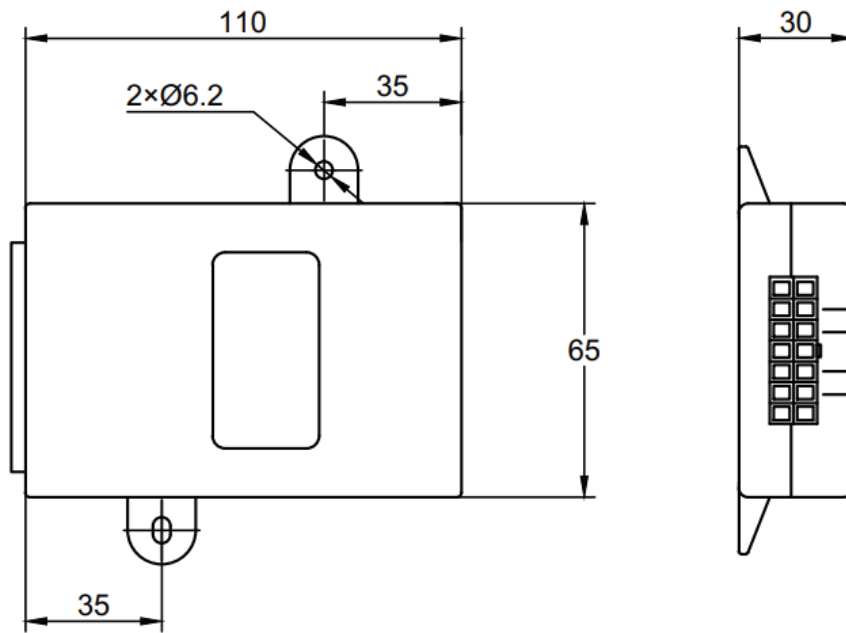

WIRING HARNESS

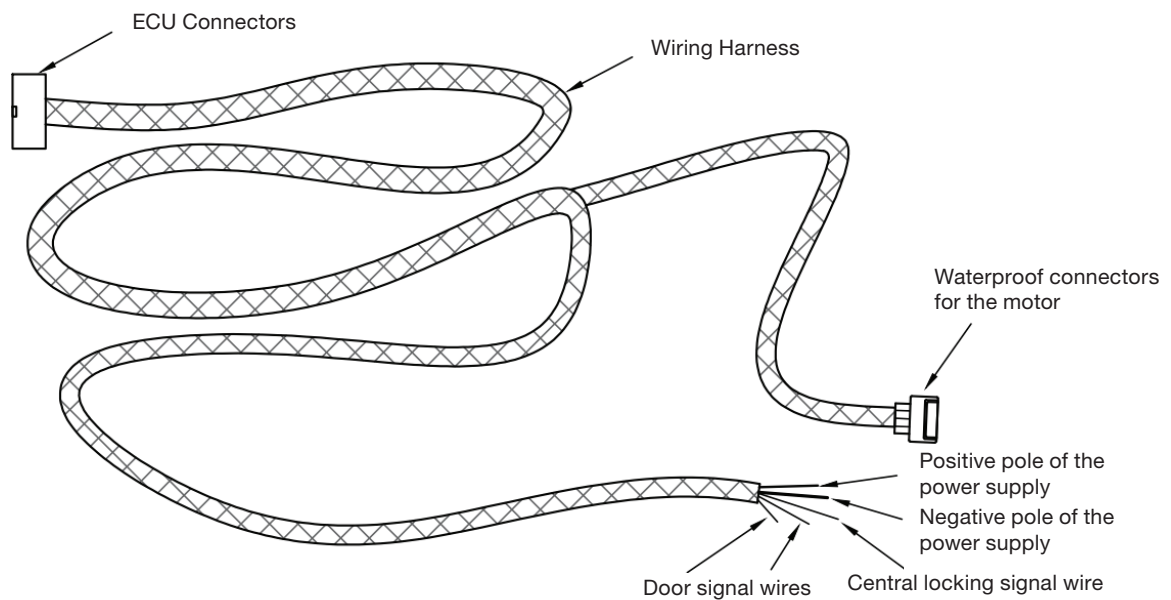

1300 663 868 | enquiries@aussietraveller.com.au | aussietraveller.com.au

BRISBANE SHOWROOM: 11-15 Oasis Court, Clontarf QLD 4019 | MELBOURNE SHOWROOM: 235 Barry Road, Campbellfield VIC 3061

PACKING LIST

STANDARD PACKING LIST:

- 1 × Premium Electric Door Step
- 1 × ECU
- 1 × Wiring Harness
- 1 × User Manual

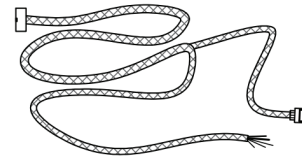
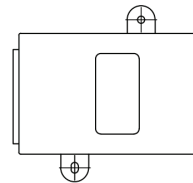
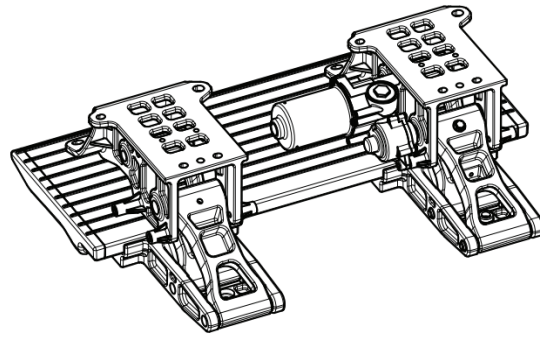

PREMIUM ELECTRIC DOOR STEP INSTALLATION

STEP ONE:

The installation position is right beneath the RV's door (as shown in the image below), and is at the central position of the door's opening.

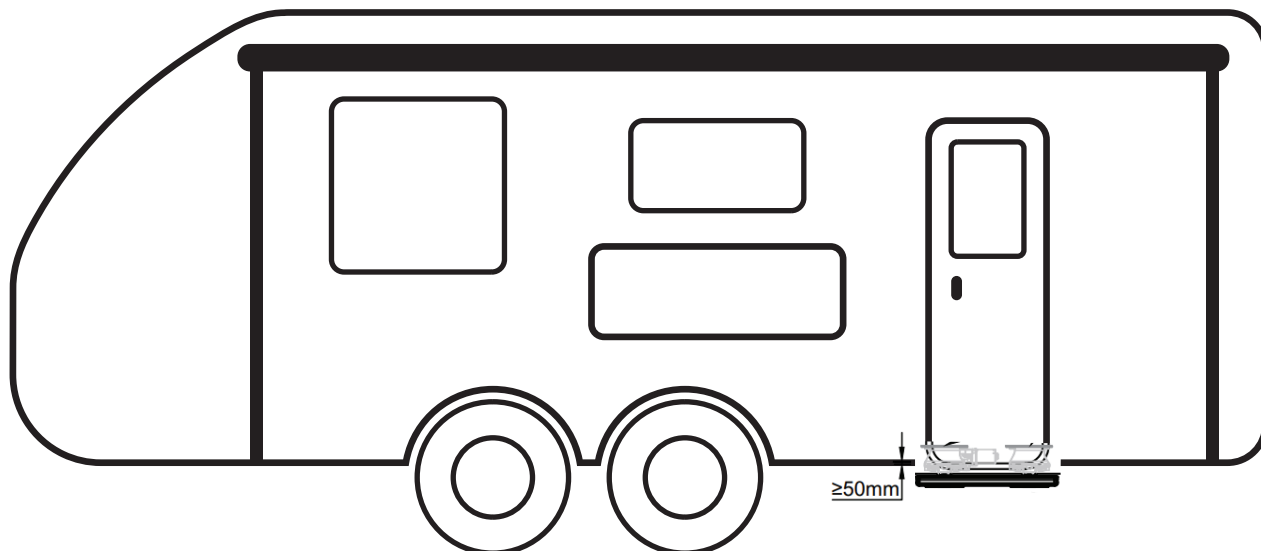

1300 663 868 | enquiries@aussietraveller.com.au | aussietraveller.com.au

BRISBANE SHOWROOM: 11-15 Oasis Court, Clontarf QLD 4019 | MELBOURNE SHOWROOM: 235 Barry Road, Campbellfield VIC 3061

PREMIUM ELECTRIC DOOR STEP INSTALLATION (cont.)

STEP TWO:

Diagrammatic Drawing of EDS Mounting Board (It's suggested to install the EDS Mounting Boards as a integrated whole so as to guarantee that the EDS installation sides are all on a same horizontal level, reducing EDS errors caused by installation).

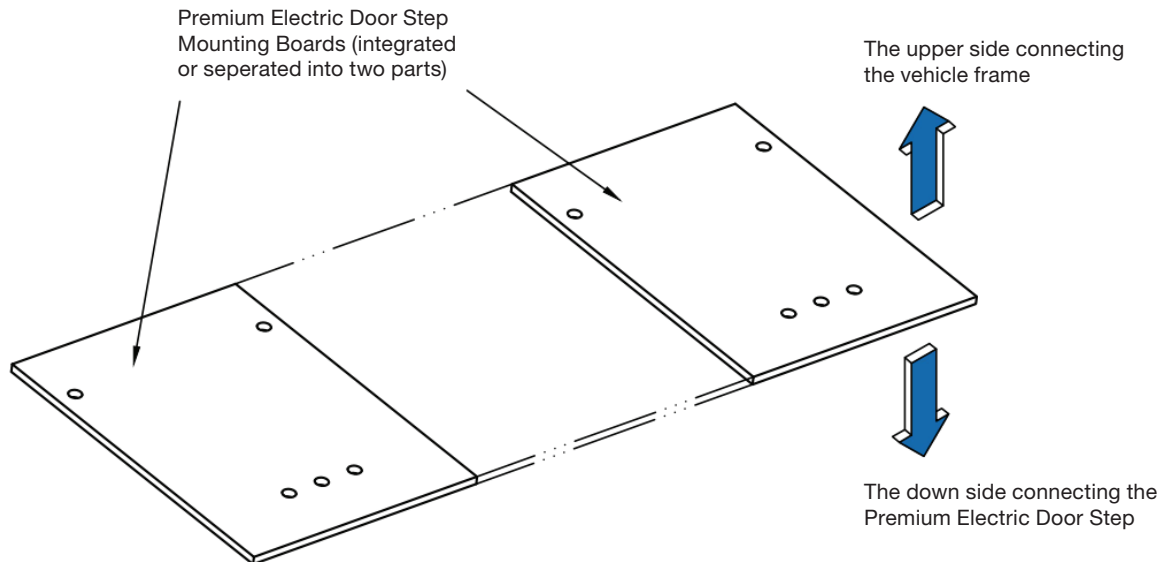

! **ATTENTION!** The distance of the step and the bottom of the vehicle shell shall be $\geq 50\text{mm}$ in case of any interference in the EDS extension against the vehicle shell!

i **NOTE:** The EDS should be kept align with the center of the door's opening and the step should be kept horizontal.

STEP THREE:

Line the EDS mounting holes up with the corresponding holes of the installation boards, and use M8×25 hexagon socket bolts(10 PCS) to fix the EDS on the installation boards

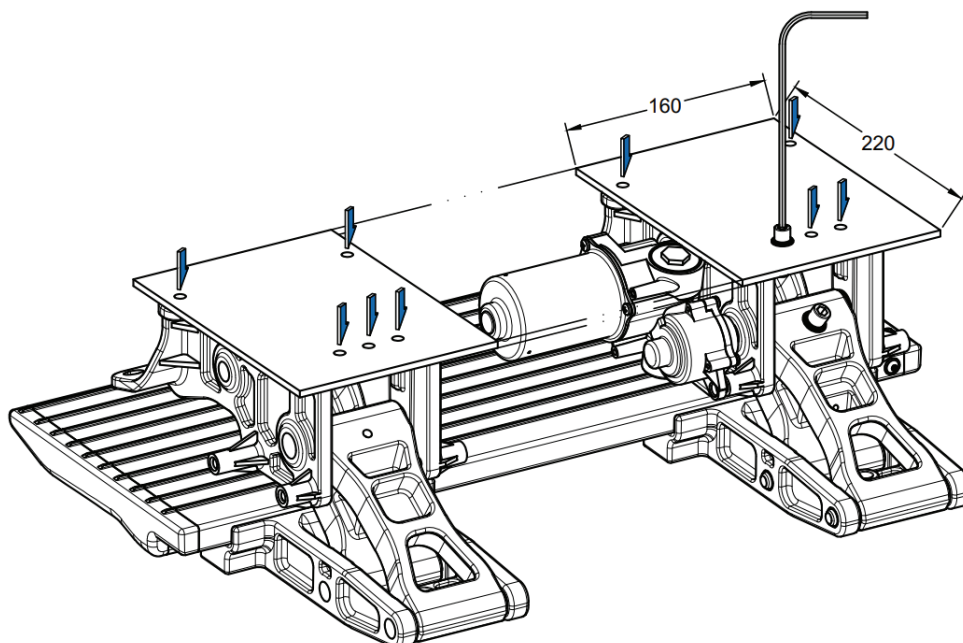

1300 663 868 | enquiries@aussietraveller.com.au | aussietraveller.com.au

BRISBANE SHOWROOM: 11-15 Oasis Court, Clontarf QLD 4019 | MELBOURNE SHOWROOM: 235 Barry Road, Campbellfield VIC 3061

PREMIUM ELECTRIC DOOR STEP INSTALLATION (cont.)

MATERIALS & TOOLS FOR MOUNTING

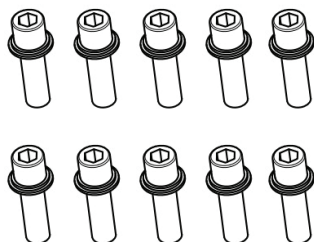

10 × M8×25 Triple combination hexagon socket bolts



1 × 6mm Allen key

NOTE: The EDS Installation Boards should be fixed at the bottom of the vehicle shell to guarantee them on the same level in case of warping after the installation.

NOTE: The ECU is not IP rated for water and must be installed within the vehicle in case of malfunction caused by water ingress.

STEP FOUR:

Connect the Door Linked Switch after installing the EDS properly, and start the EDS testing & commissioning.

TESTS		
1.	Power on the EDS, and wait for the completion of auto-learning	Initial Power-on and the CL Signal gets disconnected. Open the door, waiting for the EDS to extend to the fullest extent automatically. close the door, waiting for the EDS to retract to the fullest extent automatically. Completing the above steps represents the completion of auto-learning. No anti-pinch function in the process of auto-learning.
2.	Open & Close the door 3-5 times to check if there's any anomaly in the extension and retraction of the EDS;	Check if there's any anomaly in the linkage between the door opening and closing signals and the EDS;
3.	Step it several times after the EDS fully extended to check if any anomaly in the installation exists	Check whether the installation is completed and if there's any looseness;
4.	Use a hard object to block the extension in the middle when extending the EDS to check the anti-pinch for extension	Anti-pinch force test: the EDS will automatically retract when it gets blocked to protect the users;
5.	Use a hard object to block the retraction in the middle when retracting the EDS to check the anti-pinch for retraction	Anti-pinch force test: the EDS will extend and retract again automatically when it gets blocked, and extend and retract again (if get blocked again), and the buzzer will be buzzing in the whole process, so as to protect the users;
6.	In-off Central Locking Signal Test	Connect the CL signal to the earth wire, and retract the EDS, and the using function will be locked; Disconnect the CL signal to the earth wire, and the using function will be unlocked;

1300 663 868 | enquiries@aussietraveller.com.au | aussietraveller.com.au

BRISBANE SHOWROOM: 11-15 Oasis Court, Clontarf QLD 4019 | MELBOURNE SHOWROOM: 235 Barry Road, Campbellfield VIC 3061

TROUBLE SHOOTING

TROUBLE SHOOTING GUIDE	
PREMIUM ELECTRIC DOOR STEP FAILS TO MOVE	Check whether the power voltage of the whole vehicle is lower than 9V or more than 16V or not;
	Check whether the Waterproof connector for the motor is loose or damaged;
	Check whether the ECU box is exposed or affected by water
PREMIUM ELECTRIC DOOR STEP ANOMALY	Check whether the EDS is on the same level, and whether the whole mechanism is affected;
	Anti-pinch gets triggered by mistake. Check each rotating parts of the mechanism to see whether there's a hard object jammed in; Please clean the sand, mud, grass and other foreign matters on the EDS, and apply lubricating oil on the links after cleaning;
STEP CANNOT EXTEND OR RETRACT TO THE PRESET POSITION	Check the rotating parts of the mechanism to see whether there's a hard object jammed in;
	Please power off and re-start the EDS, and it will adjust itself to the initial position;

1300 663 868 | enquiries@aussietraveller.com.au | aussietraveller.com.au

BRISBANE SHOWROOM: 11-15 Oasis Court, Clontarf QLD 4019 | MELBOURNE SHOWROOM: 235 Barry Road, Campbellfield VIC 3061



WARRANTY STATEMENT

Aussie Traveller Pty Ltd ACN 642 775 460 (**Aussie Traveller**) offers the following warranty in relation to the products it supplies directly or through an authorised manufacturer, dealer or approved service repair agent (**Product**).

Australian Consumer Law

The benefits of this warranty are in addition to any rights and remedies imposed by Australian State and Federal legislation that cannot be excluded. Nothing in this warranty is to be interpreted as excluding, restricting or modifying any State or Federal legislation applicable to the supply of goods and services which cannot be excluded, restricted or modified.

If you are a consumer as defined in the Australian Consumer Law: *Our goods come with guarantees that cannot be excluded under the Australian Consumer Law. You are entitled to a replacement or refund for a major failure and compensation for any other reasonably foreseeable loss or damage. You are also entitled to have the goods repaired or replaced if the goods fail to be of acceptable quality and the failure does not amount to a major failure.*

Warranty

Aussie Traveller warrants that, subject to the exclusions and limitations below, all parts of the manufacture and assembly of the Product will be free from defects in materials and workmanship (**Warranty**) for a period of 12 months from the date of purchase as follows:

1. This Warranty is activated at the time of purchase by the final retail customer (being the owner of the Product).
2. In the event the Product is purchased by a manufacturer, dealer or approved service repair agent, this Warranty will commence at the time the final retail customer makes payment for the Product to the wholesale purchaser.
3. If the Product is purchased directly from Aussie Traveller for use by final retail customer and not to be on sold in any way, the Warranty will commence at the time of the original purchase.

Warranty Period

This Warranty cannot be assigned or transferred to a subsequent owner of the Product.

The purchaser or final retail customer should inspect the Product immediately when received or at vehicle handover, to ensure that it appears free from any damage or defect, and matches the description provided.

If after accepting the Product, a defect appears in the manufacture or assembly of the Product before the end of the Warranty Period and Aussie Traveller finds the Product to be defective in materials or workmanship, Aussie Traveller will, in its sole discretion, either:

- a. replace, repair or refund the Product or the defective part of the Product free of charge; or
- b. cause the Product or the defective part of the Product to be replaced or repaired by a qualified repairer free of charge.

In arranging Warranty inspection, service and repair, Aussie Traveller will seek to provide the details of an approved service agent within your geographic area. Should one not be available, or if the Product is in use in travel, Aussie Traveller reserves the right to seek to arrange a repair or replacement at the next available location on the route of travel.

Aussie Traveller reserves the right to replace defective parts of the Product with parts and components of similar quality, grade and composition where an identical part or component is not available.

Products presented for repair may be replaced by refurbished goods of the same type rather than being repaired. Refurbished parts may be used to repair the Product.

Aussie Traveller Awning Products

This Warranty covers specified defects in materials or workmanship for Awning Products as follows:

1. The vinyl fabric is warranted against:
 - a. holes caused by mildew (mildew will form on dust and dirt and stain fabric if fabric is not kept clean).
 - b. excessive cracking, peeling, hardening or loss of strength while used under normal conditions.
 - c. excessive fading (a slight colour change may occur due to ultraviolet rays).
2. All hardware components including the roller are warranted not to bend or break under normal use (excluding high winds, water pooling and accidents).

Making a Warranty Claim

If a defect covered by this Warranty appears, the Customer must first contact Aussie Traveller within 7 days of first becoming aware of the defect. Aussie Traveller will assist the Customer to rectify and resolve any Product issue that may arise.

When making a claim under this Warranty, Aussie Traveller requires that the following information be provided before any further action will be taken.

1. Original Invoice (Document or Number);
2. Make and model of the Product;
3. Make and model of the vehicle (if Product fitted);
4. Vehicle build date (if Product fitted);
5. Vehicle chassis number;
6. Description of damage and/or repair required;
7. Photos of the damage and/or repair; and
8. Appropriate documentation (such as historical and maintenance records).

Aussie Traveller reserves the right to request more information or images should what is provided not be sufficient to make an assessment for the Warranty claim.

The Product must be made available to Aussie Traveller or its authorised repair agent for inspection and testing. If such inspection and testing find no defect in the Product, the final retail customer must pay Aussie Traveller's usual costs of service work and testing.

The final retail customer must bear the cost of the transport of the Product to and from Aussie Traveller or the authorised repair agent, and all insurance of the Product.

Exclusions

This Warranty will not apply where:

- the Product has been repaired, altered or modified by someone other than Aussie Traveller, or without the written consent of Aussie Traveller or an authorised repair agent;
- the alleged defect in the Product is within acceptable industry tolerances and variances;
- Aussie Traveller cannot establish any fault in the Product after testing and inspection;
- the Product has been used other than for the purpose for which it was designed;
- the alleged defect in the Product has arisen due to the final retail customer's failure to properly use and maintain the Product in accordance with any of Aussie Traveller's instructions, recommendations and specifications (including applicable maintenance schedules);
- the alleged defect in the Product has arisen due to the final retail customer's request to customise the Product;
- the Product has been subject to abnormal conditions, including environment, temperature, high or excessive wind, water, fire, humidity, pressure, stress or similar;
- the alleged defect has arisen due to abuse, misuse, neglect or accident;
- unauthorised parts or accessories have been used on or in relation to the Product;
- the Product has been overloaded or involved in an accident;
- the alleged damage or defect has been caused by normal wear and tear;
- the alleged damage to fabric has been caused by storm, wind or rain, or stretching of fabric caused by water pooling on fabric;
- breakage or bending of hardware components has been caused by storm, wind or rain, or water pooling on fabric.

Replacement Warranty Item

If, under Warranty, a Product is replaced or repaired by Aussie Traveller or an Aussie Traveller agent, unless provided in writing to indicate otherwise, the replacement Product will carry the **remaining** Warranty terms and conditions, including length of time, of the original purchased Product.

Change of Mind

Aussie Traveller understands that at times, final retail customers may change their mind. Choose carefully as return and credit requests for items purchased by mistake or "change of mind" reasons may not be approved. Aussie Traveller will not accept Product returns under these circumstances unless by written approval by an authorized Aussie Traveller representative. If approved, an administration and restocking fee may apply.

Limitations

Aussie Traveller makes no express warranties or representations other than set out in this Warranty.

The repair or replacement of the Product or part of the Product is the absolute limit of Aussie Traveller's liability under this express Warranty.

Contact

Australia Wide: 1300 663 868

Melbourne Office

235 Barry Road
Campbellfield, Melbourne, 3061
Ph: +61 3 9357 6565
enquiries@aussietraveller.com.au

Brisbane Head Office, Factory & Showroom

11-15 Oasis Court
Clontarf, Brisbane, 4019
Ph: +61 7 3284 3284
enquiries@aussietraveller.com.au

To receive a copy of the Aussie Traveller Warranty Terms & Conditions or information regarding specific Aussie Traveller products, please contact Aussie Traveller Head Office on (07) 3284 3284 or email enquiries@aussietraveller.com.au.